

Descripción: Papelera fabricada en polietileno.

Características:

Esta papelera es resistente y económica.

Tornillería, herrajes y bisagras en acero inoxidable. Mecanismo de cierre con llave. Incluye Apaga cigarrillos en la parte superior.

Capacidad: 80 Litros.

Embalaje: Paletizado y plastificado.

Disponible en varios colores:

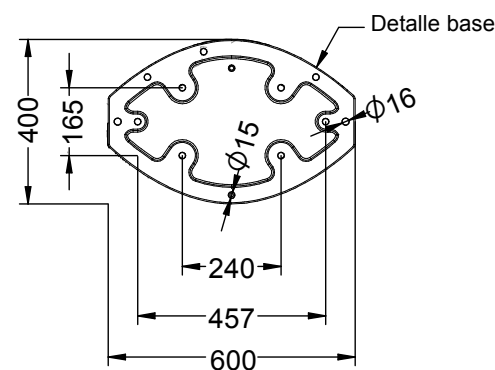
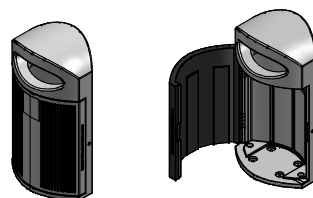

Con Apaga-colillas



GRIS (RAL 7021)



VERDE ACIDO (RAL 1026)



CORTÉN (RAL 8017)



ROJO (RAL 3020)



AZUL (RAL 5005)



NARANJA (RAL 2004)



VERDE (RAL 6029)



COBALTO (RAL 5004)

+ PRODUCTOS HAZ CLICK

